





These Conduits are made of flame-retardant Polyamide 6. They are flexible, halogen-free and have a small bending radius. They offer good impact resistance and are suitable for various applications such as ship and train building, machine building, tramway, movable machine parts, etc. These Conduits offer IP 67 protection in combination with Conduit Glands. UV resistant Conduits are also available on request. These Conduits are available in grey and black colours and comply with EN 60529 and IEC 61386 standards.

Technical Details :	
Material	Polyamide 6
Flexural Strength	850 kg / cm ²
Flexural Modulus	20,000 kg / cm ²
Tensile Strength	630 kg / cm ²
Impact Strength	20 kg / cm ²
Temperature Range	-40 ^o C to +105 ^o C Continuous, +130 ^o C Short Term
Resistant	Alcohol, Benzol, Greases, Mineral Oil, Diesel Fuel, Sea Water, Petrol, etc.
Protection Class	IP 67
Approvals	  

STANDARD POLYAMIDE FLEXIBLE CONDUITS

SLITTED / UNSLITTED



Cat. No. Grey	Cat. No. Grey Slitted	Cat. No. Black	Cat. No. Black Slitted	Inner Diameter d1 (mm)	Outer Diameter d2 (mm)	Bending Radius R (mm) ±10%	Standard Pack (meters)
		CPS-4.5B	CPSS-4.5B	5.0	7.1	12	50
CPS-07G	CPSS-07G	CPS-07B	CPSS-07B	6.4	10.0	15	50
CPS-10G	CPSS-10G	CPS-10B	CPSS-10B	9.6	13.0	20	50
CPS-12G	CPSS-12G	CPS-12B	CPSS-12B	11.8	15.8	30	50
CPS-16G	CPSS-16G	CPS-16B	CPSS-16B	15.9	21.2	40	50
CPS-22G	CPSS-22G	CPS-22B	CPSS-22B	21.7	28.5	45	50
CPS-28G	CPSS-28G	CPS-28B	CPSS-28B	27.8	34.5	55	50
CPS-36G	CPSS-36G	CPS-36B	CPSS-36B	36.0	42.5	60	30
CPS-48G	CPSS-48G	CPS-48B	CPSS-48B	46.5	54.5	70	30
CPS-56G	CPSS-56G	CPS-56B	CPSS-56B	56.3	67.2	110	30
CPS-70G	CPSS-70G	CPS-70B	CPSS-70B	70.0	82.5	160	10
CPS-95G	CPSS-95G	CPS-95B	CPSS-95B	91.5	106.0	210	10

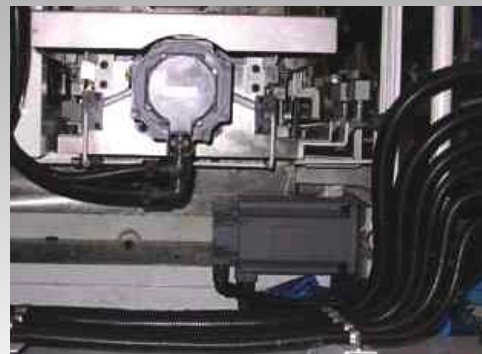
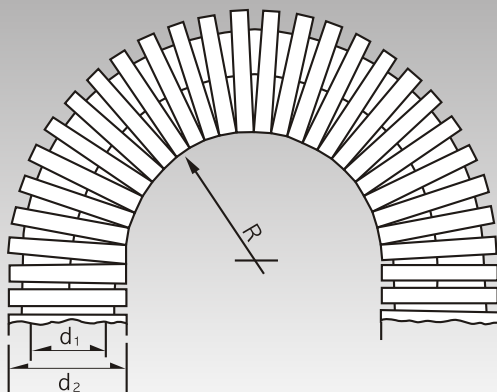

APPLICATION IMAGE

HIGH GRADE POLYAMIDE FLEXIBLE CONDUITS

SLITTED / UNSLITTED



These Conduits are made of high quality flame-retardant Polyamide 6. They are flexible, halogen-free and have a small bending radius. They also offer good impact resistance. They are suitable for various applications such as ship, train building, rolling stock, railway and subway etc. These Conduits offer IP 67 protection in combination with Conduit Glands. UV resistant Conduits are also available on request. These Conduits are available in grey and black colours and comply with EN 60529 and IEC 61386 standards.

Technical Details :	
Material	Polyamide 6
Flexural Strength	950 kg / cm ²
Flexural Modulus	26,000 kg / cm ²
Tensile Strength	700 kg / cm ²
Impact Strength	25 kg / cm ²
Temperature Range	-40° C to +105° C Continuous, +150° C Short Term
Resistant	Alcohol, Benzol, Greases, Mineral Oil, Diesel Fuel, Sea Water, Petrol, etc.
Protection Class	IP 67
Approvals	



Cat. No. Grey	Cat. No. Black	Inner Diameter d1 (mm)	Outer Diameter d2 (mm)	Bending Radius R (mm) ±10%	Standard Pack (meters)
PAH-07G	PAH-07B	6.4	10.0	15	50
PAH-10G	PAH-10B	9.6	13.0	20	50
PAH-12G	PAH-12B	11.8	15.8	30	50
PAH-16G	PAH-16B	15.9	21.2	40	50
PAH-22G	PAH-22B	21.7	28.5	45	50
PAH-28G	PAH-28B	27.8	34.5	55	50
PAH-36G	PAH-36B	36.0	42.5	60	30
PAH-48G	PAH-48B	46.5	54.5	70	30
PAH-56G	PAH-56B	56.3	67.2	110	30
PAH-70G	PAH-70B	70.0	82.5	160	10
PAH-95G	PAH-95B	91.5	106.0	210	10

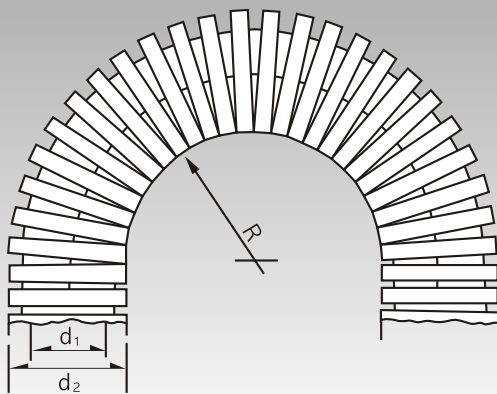

APPLICATION IMAGE



POLYETHYLENE FLEXIBLE CONDUITS

SLITTED / UNSLITTED



These Conduits are made of soft polyethylene (PE). They are flexible, and have a small bending radius offering good impact resistance. They are suitable for various applications such as machine tool, industrial machinery, chemical machinery etc. These Conduits offer IP67 protection in combination with Conduit Glands. UV resistant Conduits are also available on request. These Conduits are available in grey and black colours and comply with EN 60529 and IEC 61386 standards.

Technical Details :	
Material	Polyethylene (PE)
Flexural Strength	500 kg / cm ²
Flexural Modules	16,000 kg / cm ²
Tensile Strength	520 kg / cm ²
Impact Strength	15 kg / cm ²
Temperature Range	-15 ^o C to +60 ^o C Continuous, +80 ^o C Short Term
Resistant	Acid, Sea Water, Ammonia, etc.
Protection Class	IP 67

Cat. No. Grey	Cat. No. Grey Slitted	Cat. No. Black	Cat. No. Black Slitted	Standard Pack (meters)	Inner Diameter d1 (mm)	Outer Diameter d2 (mm)	Bending Radius R (mm) ± 10%
		PES-4.5B	PESS-4.5B	50	5.0	7.1	12
PES-07G	PESS-07G	PES-07B	PESS-07B	50	6.4	10.0	15
PES-10G	PESS-10G	PES-10B	PESS-10B	50	9.6	13.0	20
PES-12G	PESS-12G	PES-12B	PESS-12B	50	11.8	15.8	30
PES-16G	PESS-16G	PES-16B	PESS-16B	50	15.9	21.2	40
PES-22G	PESS-22G	PES-22B	PESS-22B	50	21.7	28.5	45
PES-28G	PESS-28G	PES-28B	PESS-28B	50	27.8	34.5	55
PES-36G	PESS-36G	PES-36B	PESS-36B	30	36.0	42.5	60
PES-48G	PESS-48G	PES-48B	PESS-48B	30	46.5	54.5	70
PES-56G	PESS-56G	PES-56B	PESS-56B	30	56.3	67.2	110
PES-70G	PESS-70G	PES-70B	PESS-70B	10	70.0	82.5	160
PES-95G	PESS-95G	PES-95B	PESS-95B	10	91.5	106.0	210

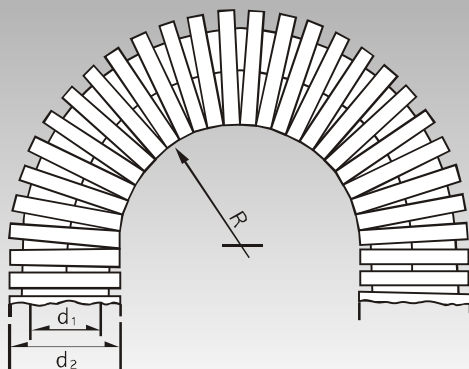

APPLICATION IMAGE

This document was created with Win2PDF available at <http://www.win2pdf.com>.
The unregistered version of Win2PDF is for evaluation or non-commercial use only.
This page will not be added after purchasing Win2PDF.